

FZRN21-40.5/50-20 Vacuum Disconnect Load Break Switch-Fuse Combination Apparatus

Summary

FZRN21-40.5/50-20 vacuum disconnect load break switch-fuse combination apparatus is applied in 40.5kV substation, small volume, convenience for installation, especially for no power-supply area, it is easy and safe for changing the fuse.



Ambient condition

1. Altitude: $\leq 1000\text{m}$;
2. Ambient temperature: $-40^{\circ}\text{C}\sim+40^{\circ}\text{C}$;
3. Relative humidity: daily average $\leq 95\%$, monthly average $\leq 90\%$;
4. Earthquake intensity: ≤ 8 degree;
5. Pollution degree: III.

Structure feature

The short-circuit breaking current can up to 20kA, long mechanism life, there is an security linkage between main switch, disconnect blade and earthing blade, it can operate frequently. It according to the standard of GB16927 & IEC62271-105.

Technical specification

FZ(R)N21-40.5/50-20 load break switch-fuse

No.	Item	Unit	Combination apparatus	Load break switch
1	Rated voltage	kV	40.5	40.5
2	Rated current	A	50	1250
3	Rated power frequency	Hz	50/60	50/60
4	Rated short-circuit breaking current	kA	20	-
5	Rated short-circuit making current		-	40
6	Rated peak withstand current		-	40
7	Rated short-time withstand current		-	16
8	Rated transfer current	A	2000	-
9	Rated connect current		2000	-
10	Rated active load breaking current		-	1250
11	Rated short-circuit duration	s	-	4
12	Rated short-time(1min) P.F. withstand voltage	kV	phase to phase, to earth and normal gaps: 95	
			between gaps: 115	
13	Rated lightning impulse withstand voltage(peak)	kV	phase to phase, to earth and normal gaps: 185	
			between gaps: 215	
14	Circuit resistance	$\mu\Omega$	80	80

Technical parameters of FZ(R)N21-40.5/63-31.5

No.	Item	Unit	Combination apparatus	Load break switch
1	Clearance of opening contact	mm	17 ± 1	
2	Average opening speed	m/s	1.6 ± 0.2	
3	Average closing speed		0.8 ± 0.2	
4	Rated contact pressure	N	1000 ± 150	
5	Contact closing trip time	ms	≤ 2	
6	Central distance between poles	mm	410 ± 2	
7	Air clearance across contacts		300	
8	Manual operating moment	N · m	≤ 250	
9	Mechanical life	Times	10,000	

Outline dimension

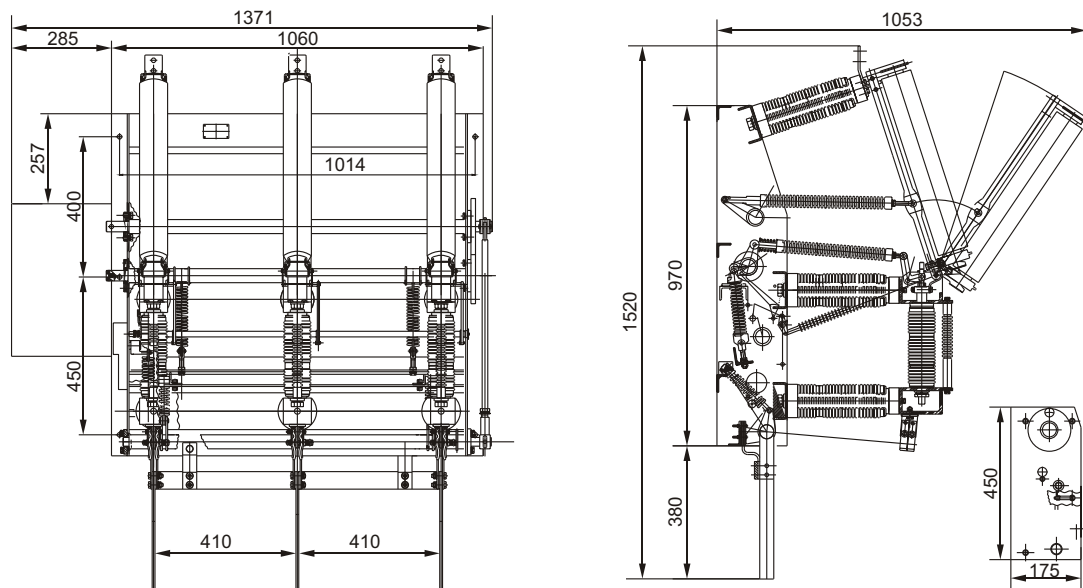

Diagram 1 FZR21-40.5/50-20 Outline dimension

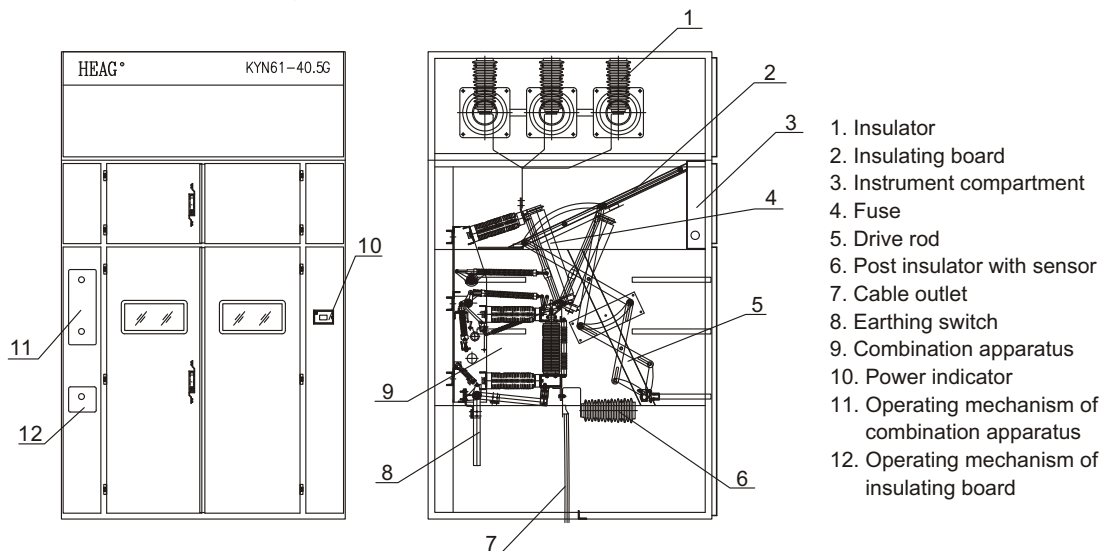

Diagram 2 FZR21-40.5 Into cubicle switchgear (KYN61) internal structure chart